

# Paper Planes

Most young people can make a paper plane which in effect is probably a paper dart rather than a true paper glider. There are numerous other designs rather than the simple paper dart, each with its own unique characteristic. Some are built to glide other have stunt capabilities others are long distance machines. Apart from the paper folding skills such an exercise can develop there are also the understanding of aerodynamics. When the planes have been built you can hold a contest to discover the plane that can do - the longest flight, the best stunts or the best landing.

## Throwing skills

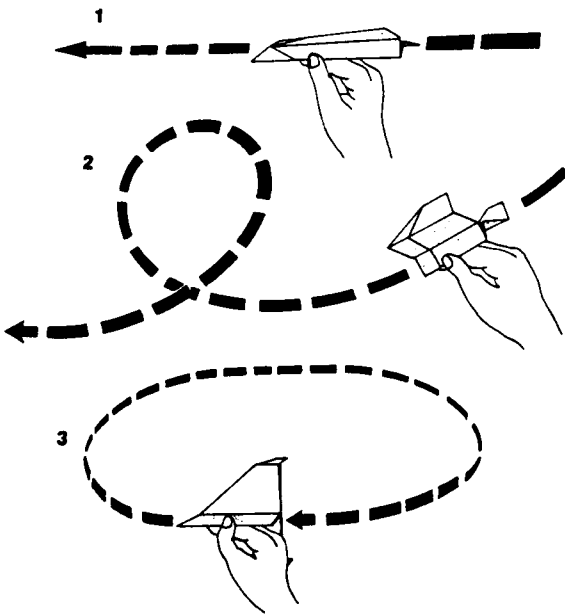

## Stingray Glider

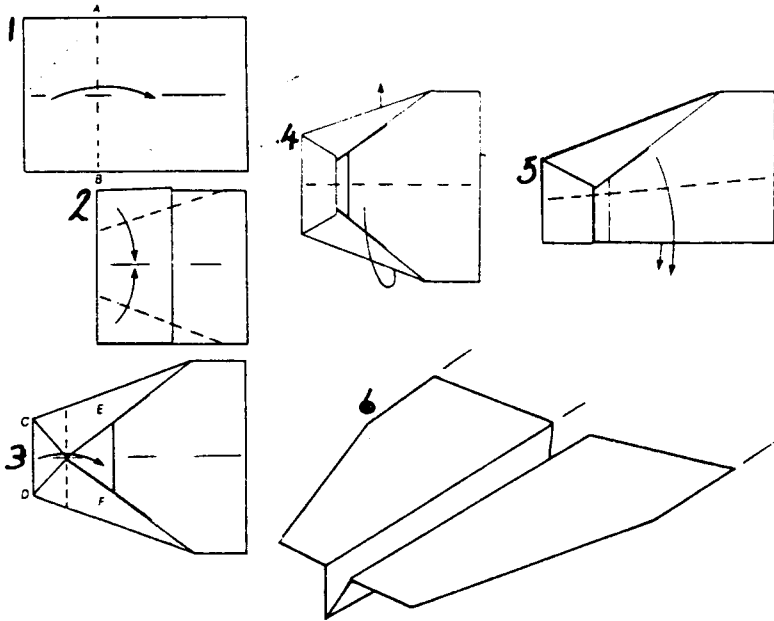

## Dart Fighter

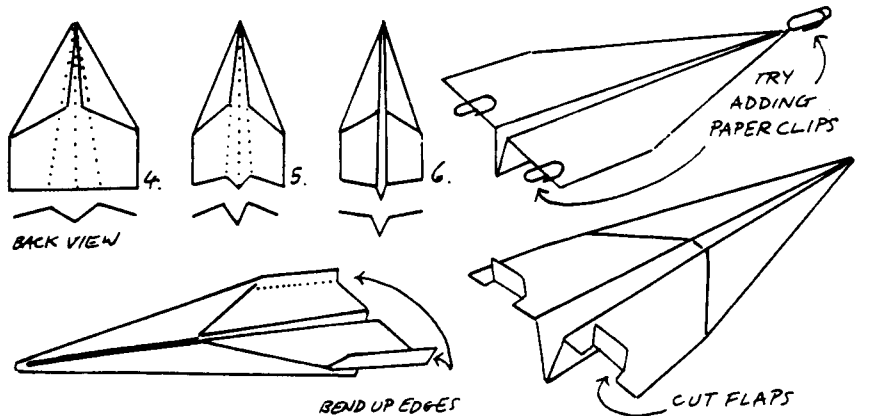

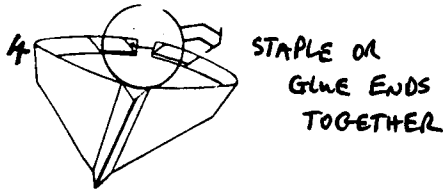
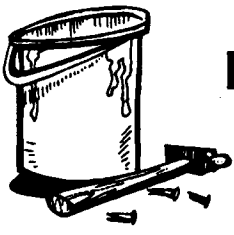

Space fighter

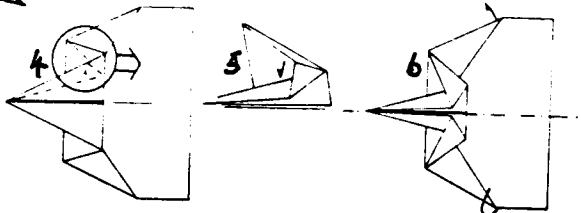
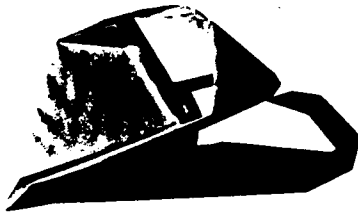
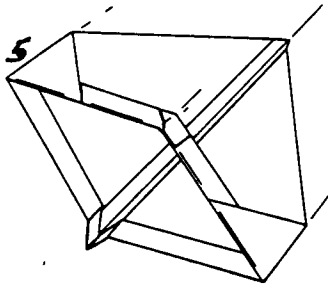
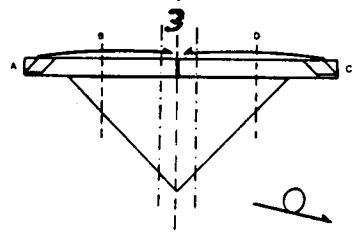
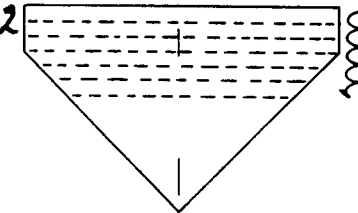
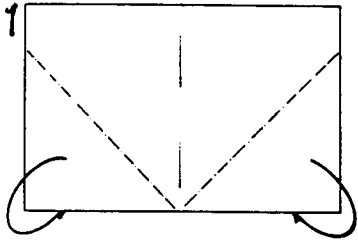

The Swooper

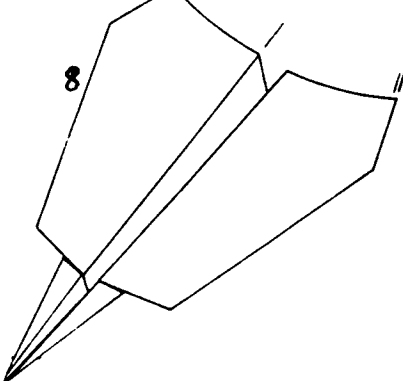
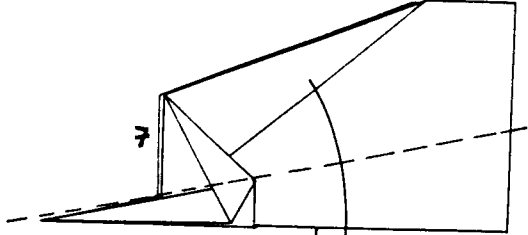
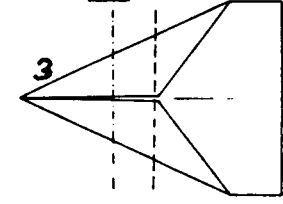
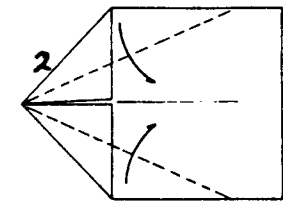
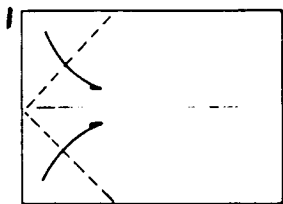

The flyer

